

MANUAL DE MONTAGEM  
Assembly instructions / Instrucciones de armado

BAR LAGUNA

Bar Laguna  
Bar Laguna

Código 2285 | Revisão 06

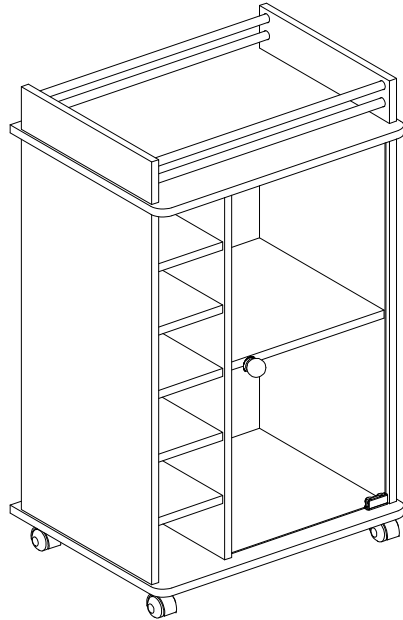

PESO MÁXIMO SUPORTADO PELAS PEÇAS, SENDO ESTE DISTRIBUÍDO UNIFORMEMENTE.

Maximum weight supported by parts, being this evenly distributed.  
Peso máximo soportado por las partes, siendo esta distribuido uniformemente.

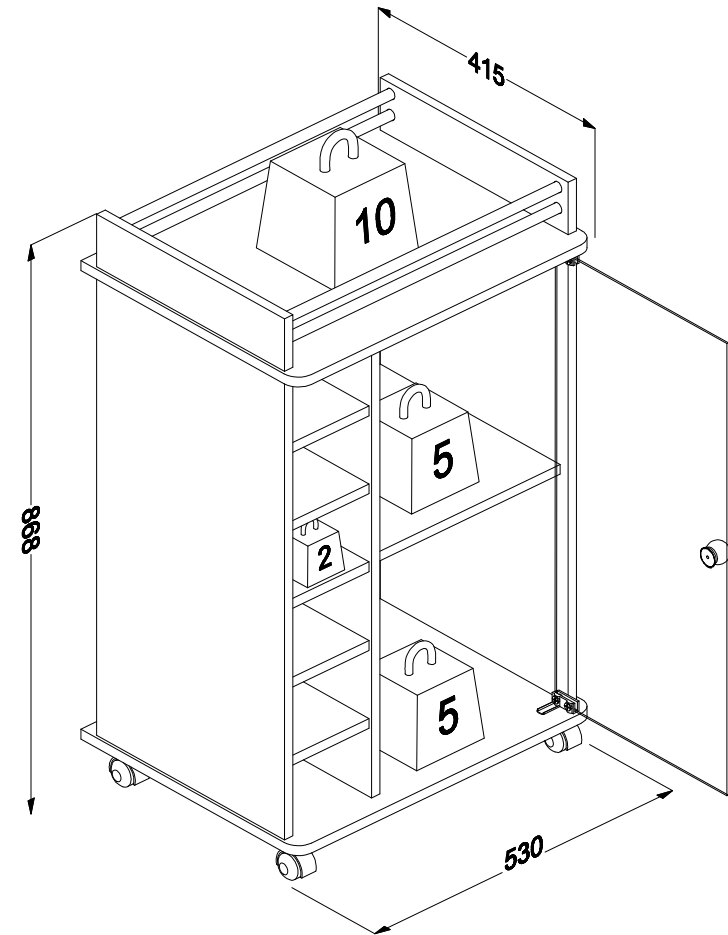

Você vai precisar de/ You will need / Usted necesitará

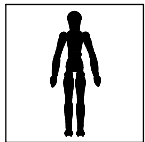

1 Pessoa  
1 person  
1 persona

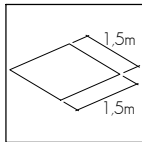

Espaço recomendado para montagem  
Recommended space for assemble  
Espacio recomendado para el armado

Ferramentas não inclusas  
Tools not included / Herramientas no incluidas

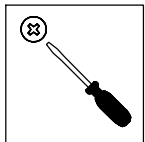

Chave Philips  
Screwdriver  
Destornillador cruz

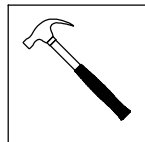

Martelo  
Hammer  
Martillo

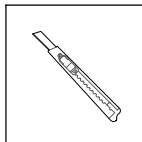

Estilete  
Stylet  
Estilete











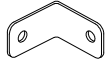
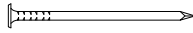

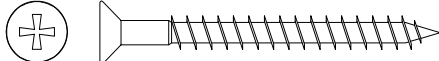
\* PESO EM KG/ Weight in Kg/ Peso en Kg  
DIMENSÕES EM MM/ Dimensions in mm/ Dimensiones en mm

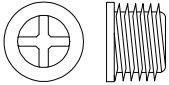
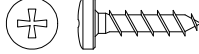
**IDENTIFICAÇÃO DOS ACESSÓRIOS/ IDENTIFICATION OF ACCESSORIES/ IDENTIFICACIÓN DE ACCESORIOS**

**NOTAS:** A separação dos acessórios antes de iniciar a montagem facilitará a mesma. Os parafusos e cavilhas estão na escala real. Em caso de dúvida na identificação, coloque o acessório sobre a imagem.

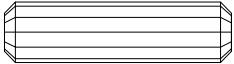
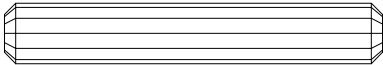
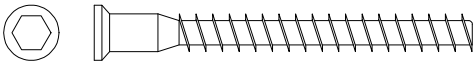
**NOTES:** The separation of the accessories before you start the assembly will facilitate the same. The screws and dowels are in real scale. In case of doubts about the identification, place the accessory on the image.

**NOTAS:** La separación de los accesorios antes de comenzar el armado facilitará el mismo. Los tornillos y taquetes son en escala real. En caso de dudas sobre la identificación, coloque el accesorio en la imagen.

A4		<b>Cantoneira de metal</b> Metal bracket Soporte de metal	22x22 mm	<b>04</b>	N		<b>Prego</b> Nail Clavo	10 x10	<b>20</b>
B8		<b>Suporte de prateleira</b> Shelf bracket Soporte de repisa	10x15 mm	<b>01</b>	O		<b>Parafuso chato</b> Flat head screw Tornillo de cabeza plana	4,5x45 mm	<b>10</b>
B9		<b>Arruela de borracha</b> Rubber washer Arandela de goma	-	<b>01</b>	Q3		<b>Roliço plastificado</b> Laminated plump Regordete laminado	-	<b>04</b>
C3		<b>Parafuso dobradiça nylon</b> Nylon hinge screw Tornillo bisagra de nylon	10x8 mm	<b>04</b>	S		<b>Parafuso panela</b> Pan head screw Tornillo de pan	3,5x14 mm	<b>26</b>
C4		<b>Bucha sup. dobradiça nylon</b> Upper hinge bushing nylon Buje sup. bisagra de nylon	-	<b>02</b>					
C5		<b>Dobradiça nylon "A"</b> Nylon hinge "A" Bisagra de nylon "A"	-	<b>01</b>					
C6		<b>Dobradiça nylon "B"</b> Nylon hinge "B" Bisagra de nylon "B"	-	<b>01</b>					
C7		<b>Bucha inf. dobradiça nylon</b> Lower hinge bushing nylon Buje inf. bisagra de nylon	-	<b>01</b>					
E		<b>Cavilha</b> Wooden Dowel Pin	8x30 mm	<b>28</b>					
F		<b>Cavilha</b> Wooden Dowel Pin	8x50 mm	<b>06</b>					
G		<b>Parafuso estrutural</b> Structural screw Tornillo estructural	5,0x50 mm	<b>06</b>					
H		<b>Chave allen</b> Allen key Llave Allen	5,0x50 mm	<b>01</b>					
H5		<b>Puxador</b> Handle Tirador	-	<b>01</b>					
H6		<b>Rodizio</b> Caster Ruedas	-	<b>04</b>					
I		<b>Tampa parafuso estrutural</b> Structural screw cover Tapa tornillo estructural	-	<b>04</b>					

IDENTIFICAÇÃO DAS PEÇAS/ PARTS IDENTIFICATION/ IDENTIFICACIÓN DE LAS PIEZAS

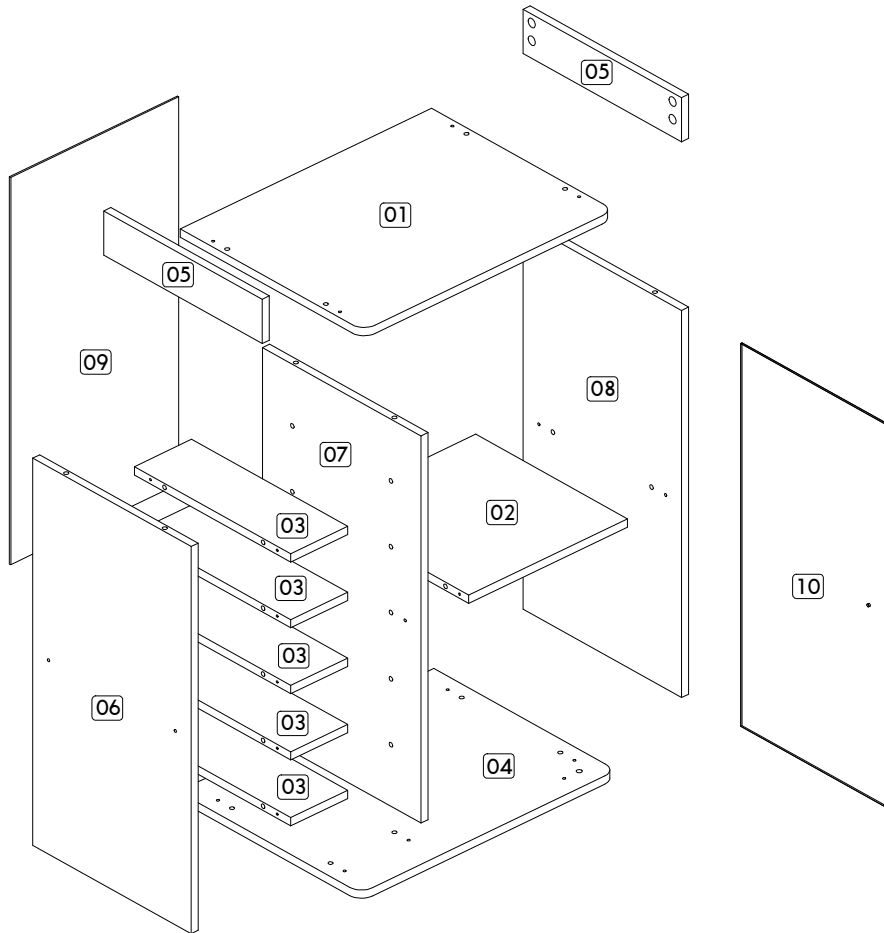

Nº	DESCRIÇÃO - DESCRIPTION - DESCRIPCIÓN	MEDIDAS-MEASURES - MEDIDAS (mm)	QTD.
01	<b>Base superior</b> - Top base - Base superior	530 x 415 x 15	01
02	<b>Prateleira maior</b> - Bigger shelf - Repisa mayor	335 x 345 x 15	01
03	<b>Prateleira menor</b> - Smaller shelf - Repisa menor	355 x 140 x 15	05
04	<b>Base inferior</b> - Bottom base - Base inferior	530 x 415 x 15	01
05	<b>Lateral superior</b> - Top side - Lateral superior	360 x 80 x 15	02
06	<b>Lateral esquerda</b> - Left side - Lateral izquierda	700 x 360 x 15	01
07	<b>Divisão</b> - Division - División	700 x 360 x 15	01
08	<b>Lateral direita</b> - Right side - Lateral derecha	700 x 360 x 15	01
09	<b>Costa armário</b> - Back cabinet - Fondo del armário	700 x 355 x 3	01
10	<b>Porta de vidro</b> - Glass door - Puerta de vidrio	692 x 329 x 3	01

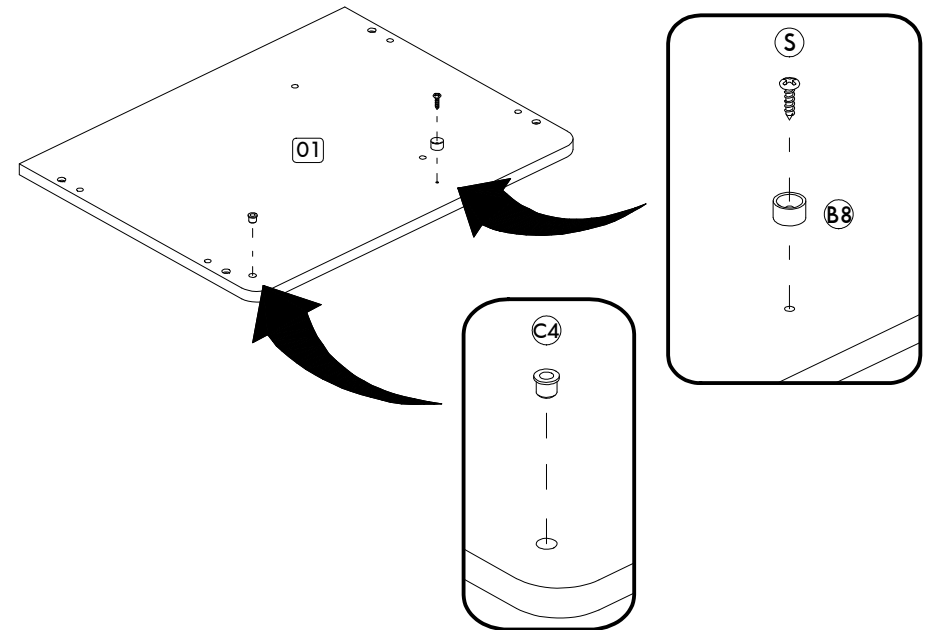
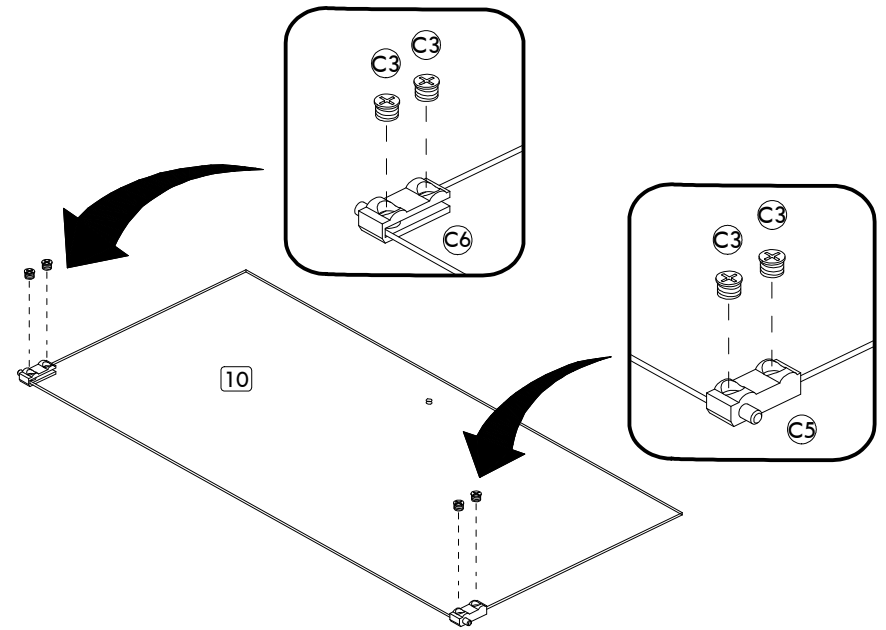
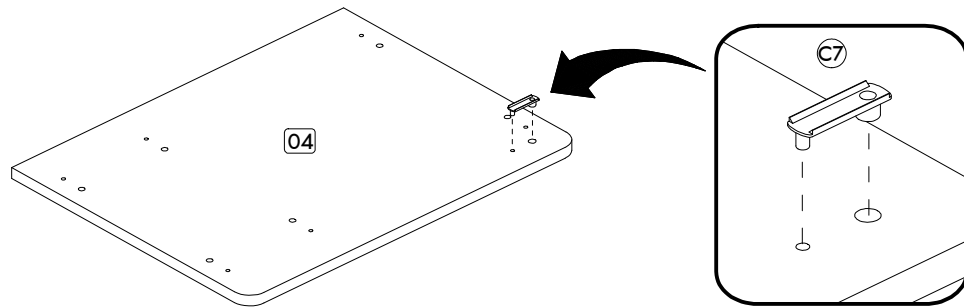
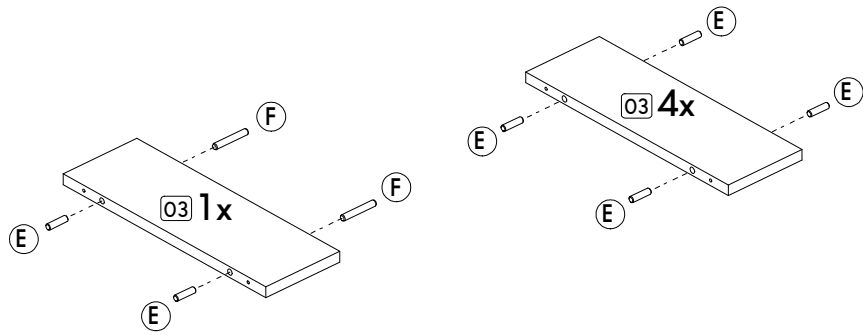

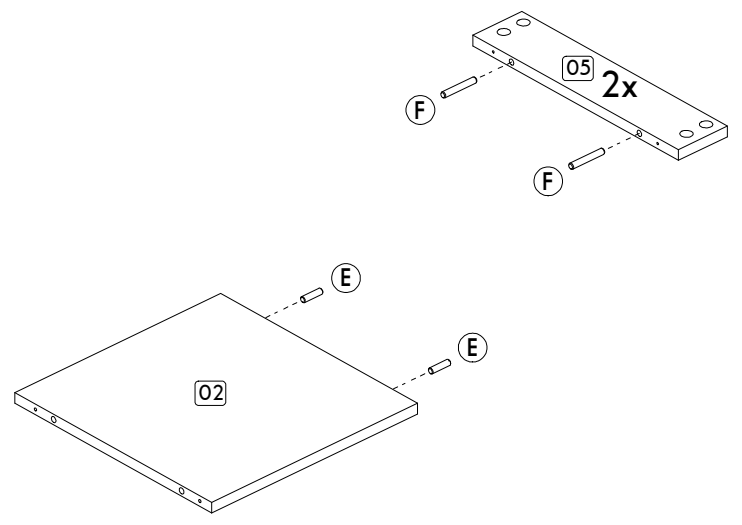
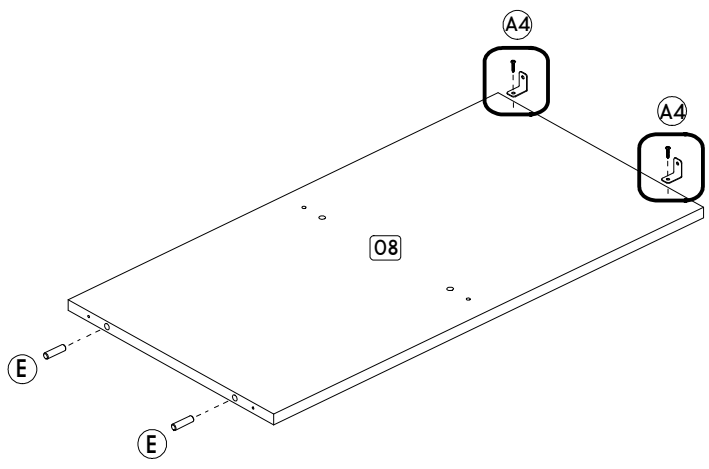
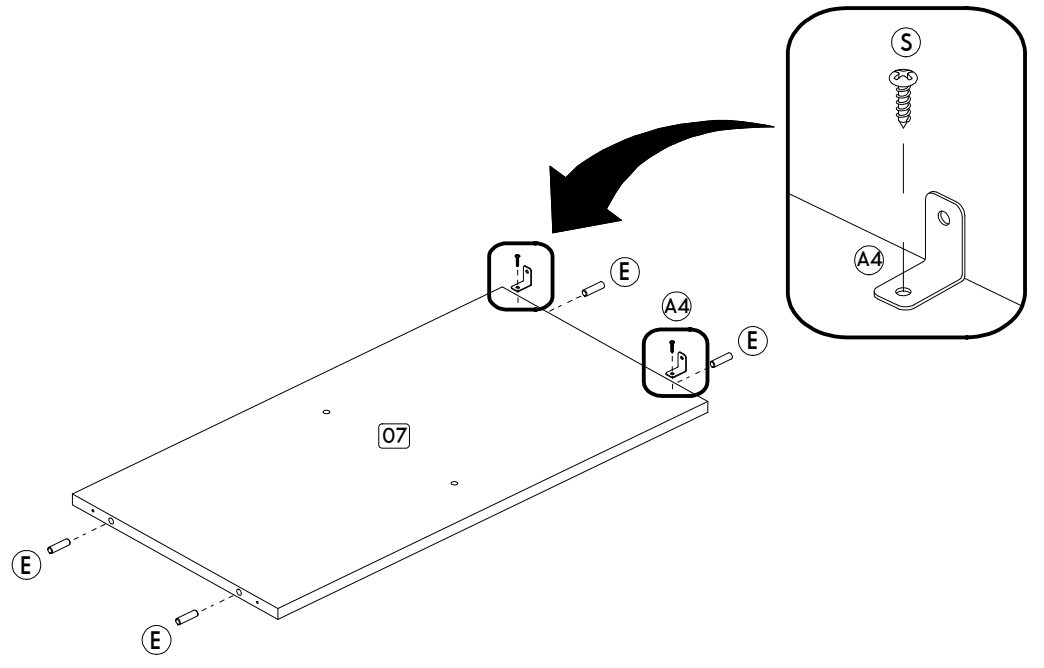
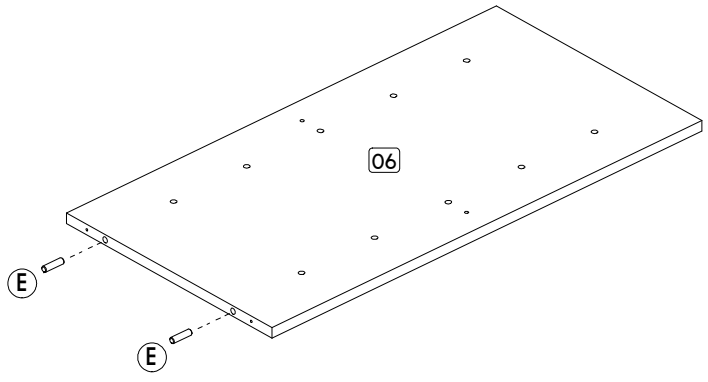

Passo/ Step/ Paso 01

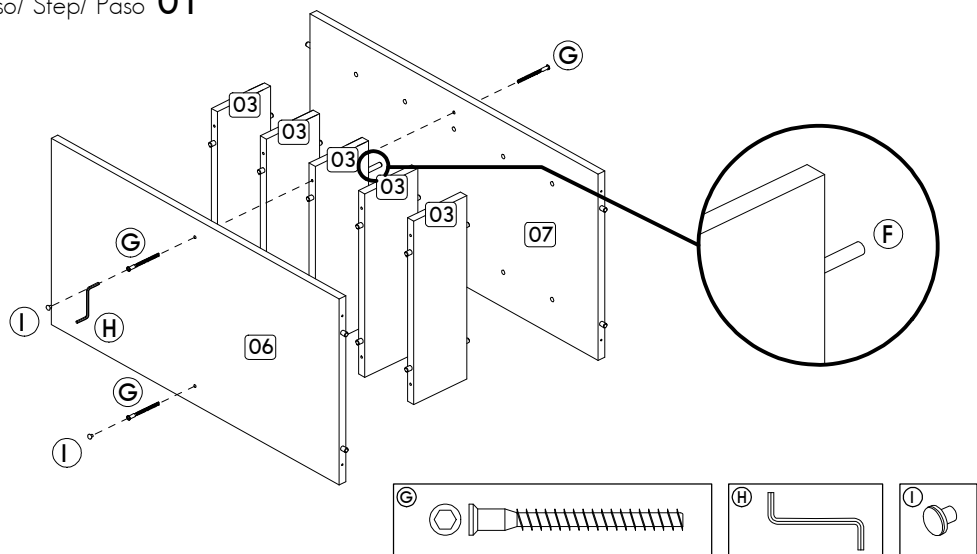

Passo/ Step/ Paso 02

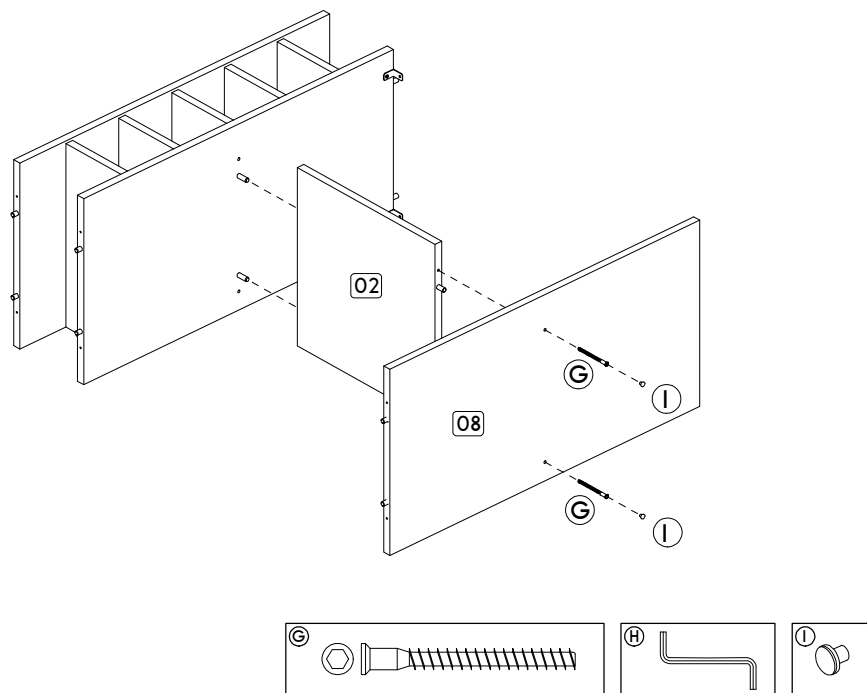

Passo/ Step/ Paso 03

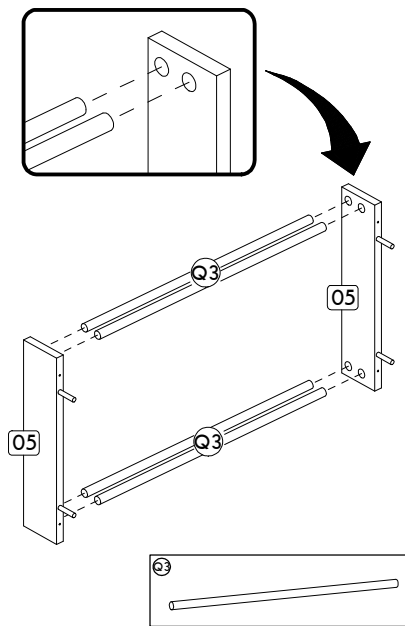

Passo/ Step/ Paso 04

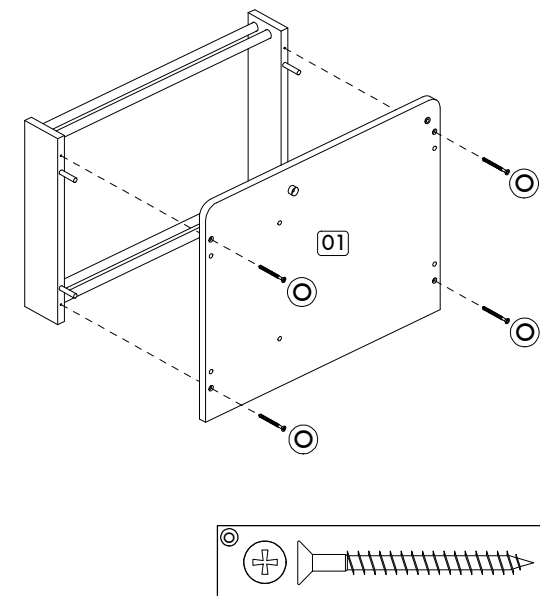

Passo/ Step/ Paso 05

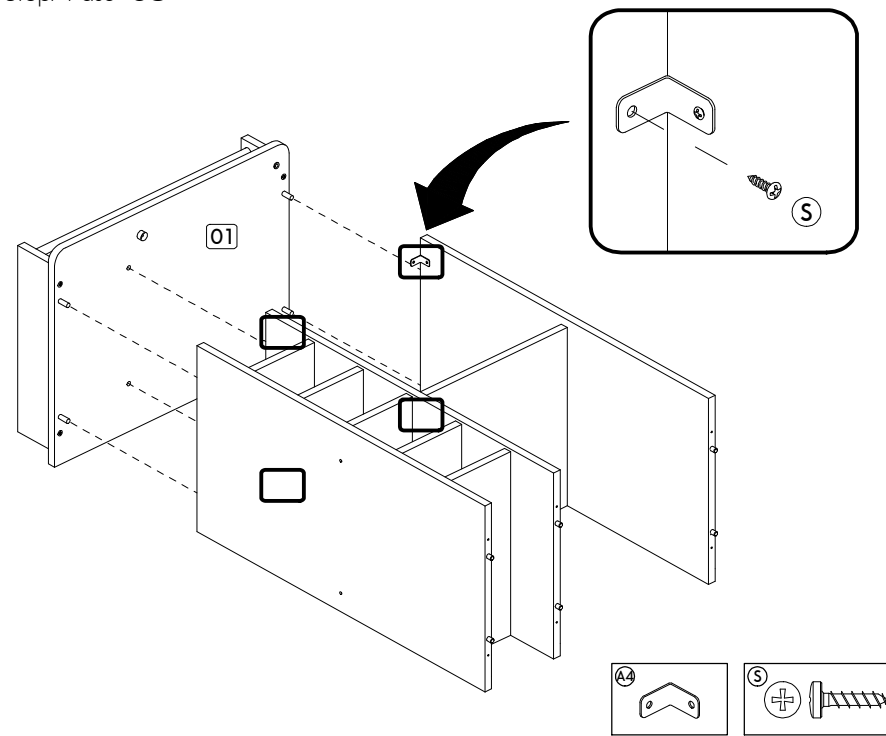

Passo/ Step/ Paso 06

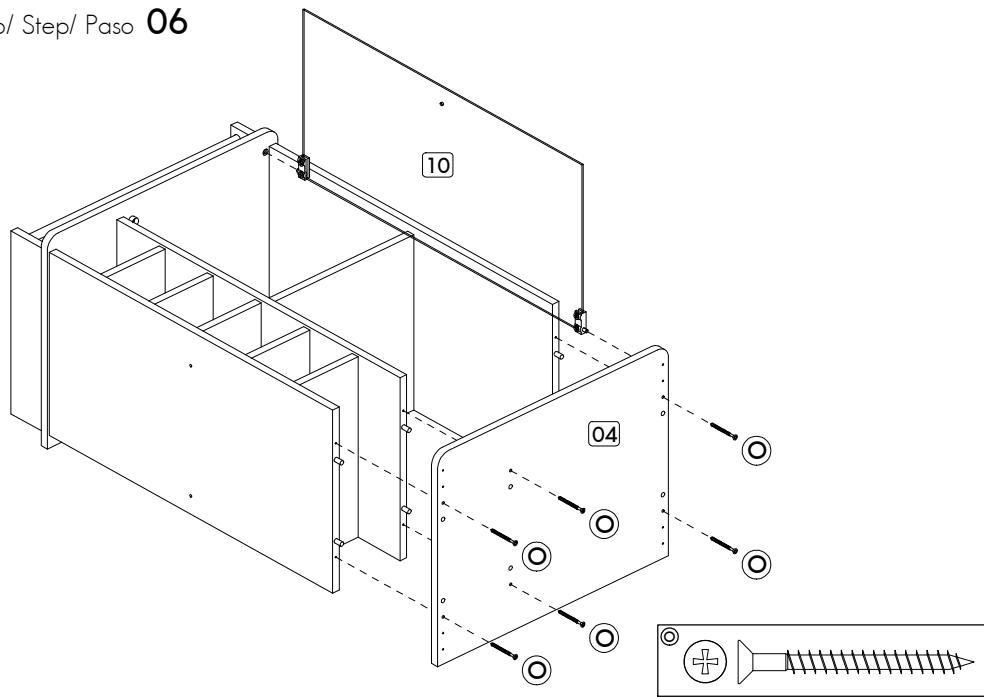

Passo/ Step/ Paso 07

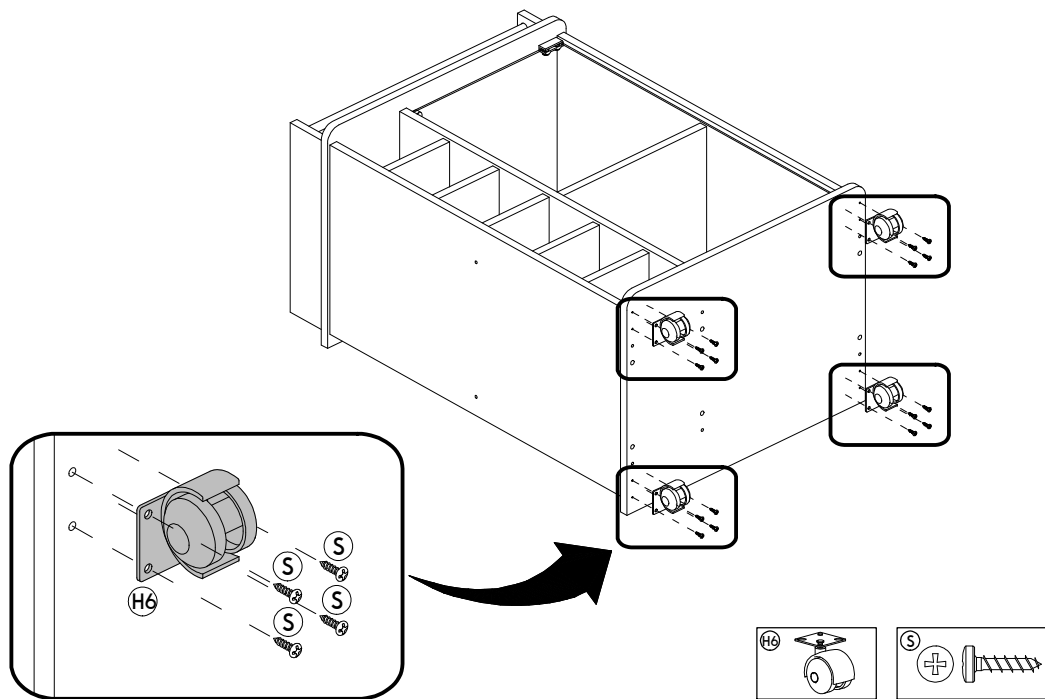

Passo/ Step/ Paso 08

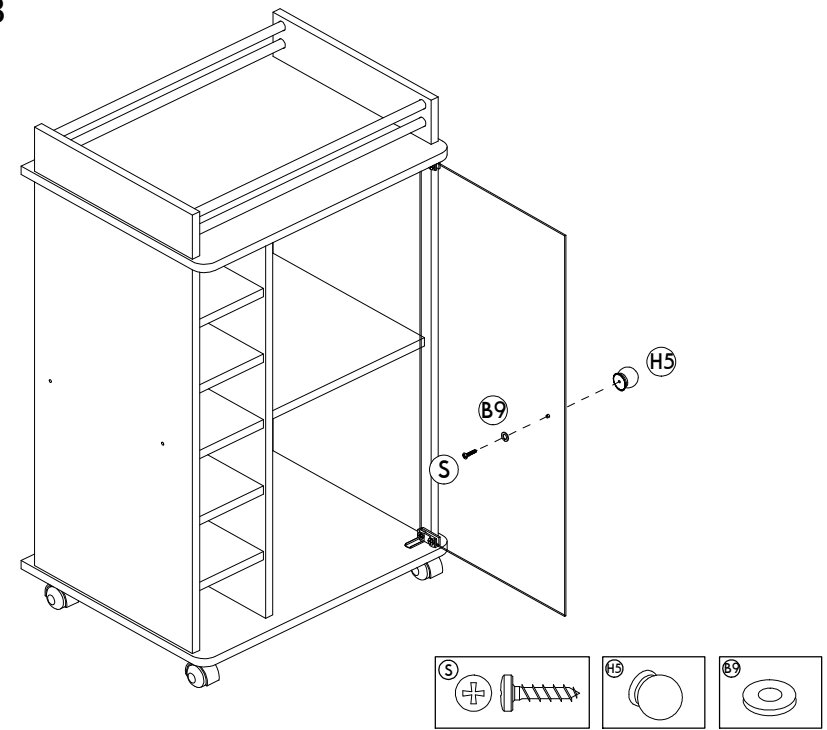

Passo/ Step/ Paso 09

