

INVAL

El mueble que uno quiere
Furniture that you want

REF.: AM 5423

ARMOIRE

ARMARIO

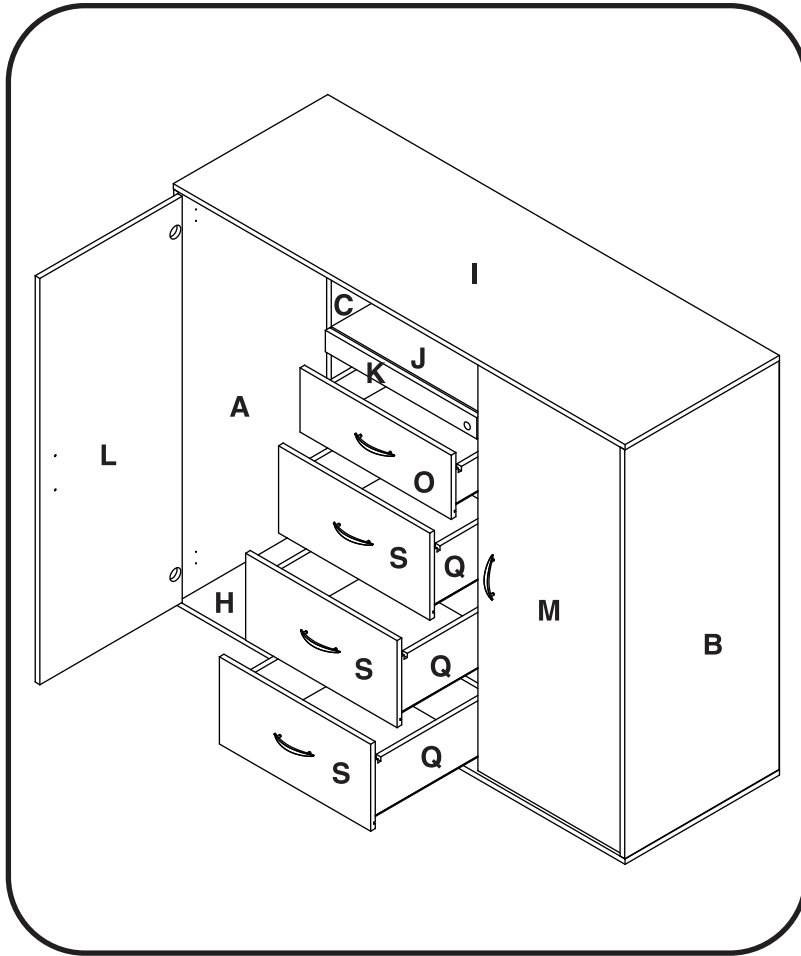

This instruction manual contains important information. Follow the consecutive order. Please read and keep for future reference.

Este Manual contiene información importante. Siga el orden consecutivo de las instrucciones.

Por favor léalo y guárdelo para consultas en el futuro.



Two or more people are required to assemble and/or move this unit.
Se requiere de dos o más personas para armar y mover este mueble.



Unpack and assemble this unit in an spacious area. Assemble the unit on top of the empty box to prevent scratches.
Desempaque y arme este mueble en un area espaciosa. Arme el mueble sobre su caja, para no rayarlo.



Protect furniture from water and moisture. This furniture must not be used outdoors.
Proteja el mueble del agua y de la humedad. No use este mueble al aire libre.



Do not expose it to heat.
No lo exponga al calor.



Do not hit or tap with a hammer, unless it is indicated.
No lo golpee ni lo martille.



Do not paint or use abrasive elements to clean this furniture.
No pinte ni use elementos abrasivos para limpiar este mueble.



Do not drag or climb on your furniture. If you need to move it, lift it.
No lo arrastre ni se suba al mueble. Si necesita moverlo, levántelo.



Certificado Nº sc 640-1



PARTS IDENTIFICATION / IDENTIFICACIÓN DE PARTES

EXPLODED VIEW/DESPIECE

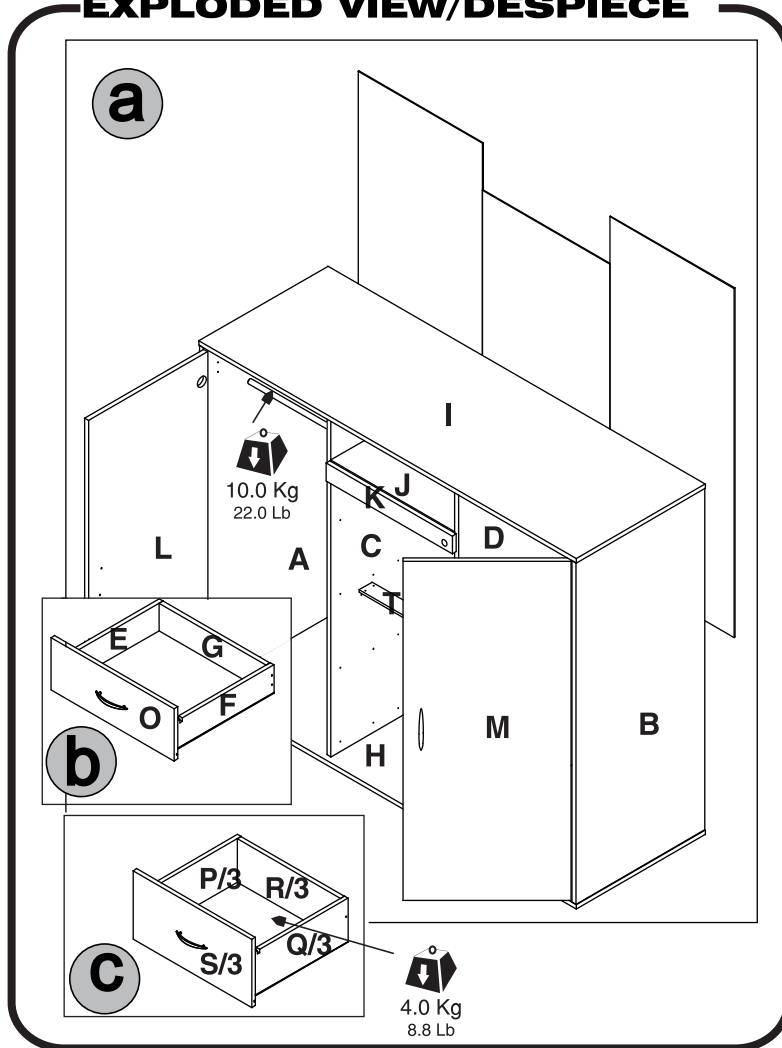

PARTS LIST TABLA DE PIEZAS

PARTS PIEZA	QUANTITY CANTIDAD
A	1
B	1
C	1
D	1
E	1
F	1
G	1
H	1
I	1
J	1
K	1
L	1
M	1
O	1
P	3
Q	3
R	3
S	3
T	1
ESPALDARES	3
FONDOS GAVETA	4

QUANTITY CANTIDAD	FROM DESDE	TO HASTA
34	A	T

IDENTIFICACIÓN DE HERRAJES HARDWARE IDENTIFICATION



IMPORTANT: Before proceeding to assemble this unit, read the instructions and inspect carefully the parts and hardware thoroughly. If any part is missing, do not return to the store, please call toll free: In Colombia 01800 09 33444, Venezuela 0212-238-7584, Mexico 53447019 / 53445841 and in the USA, Canada, Puerto Rico and US Virgin Islands visit our Web page www.invalamerica.com.

IMPORTANTE: Antes de empezar a ensamblar este mueble, lea este instructivo y revise cuidadosamente las piezas y herrajes. En caso de que le haga falta alguna pieza, no lo devuelva a la tienda, favor llamar a la línea gratuita en Colombia Colombia 01800 09 33444, Venezuela 0212-238-7584, Mexico 53447019 / 53445841 y para USA, Canada, Puerto Rico y US Virgin Islands visite nuestra página Web www.invalamerica.com.

ASSEMBLY STEPS / PASOS PARA ENSAMBLAR 1

PARTS SET UP / PREPARACIÓN DE PIEZAS

**FURNITURE ASSEMBLY
ARMADO DEL MUEBLE**

a

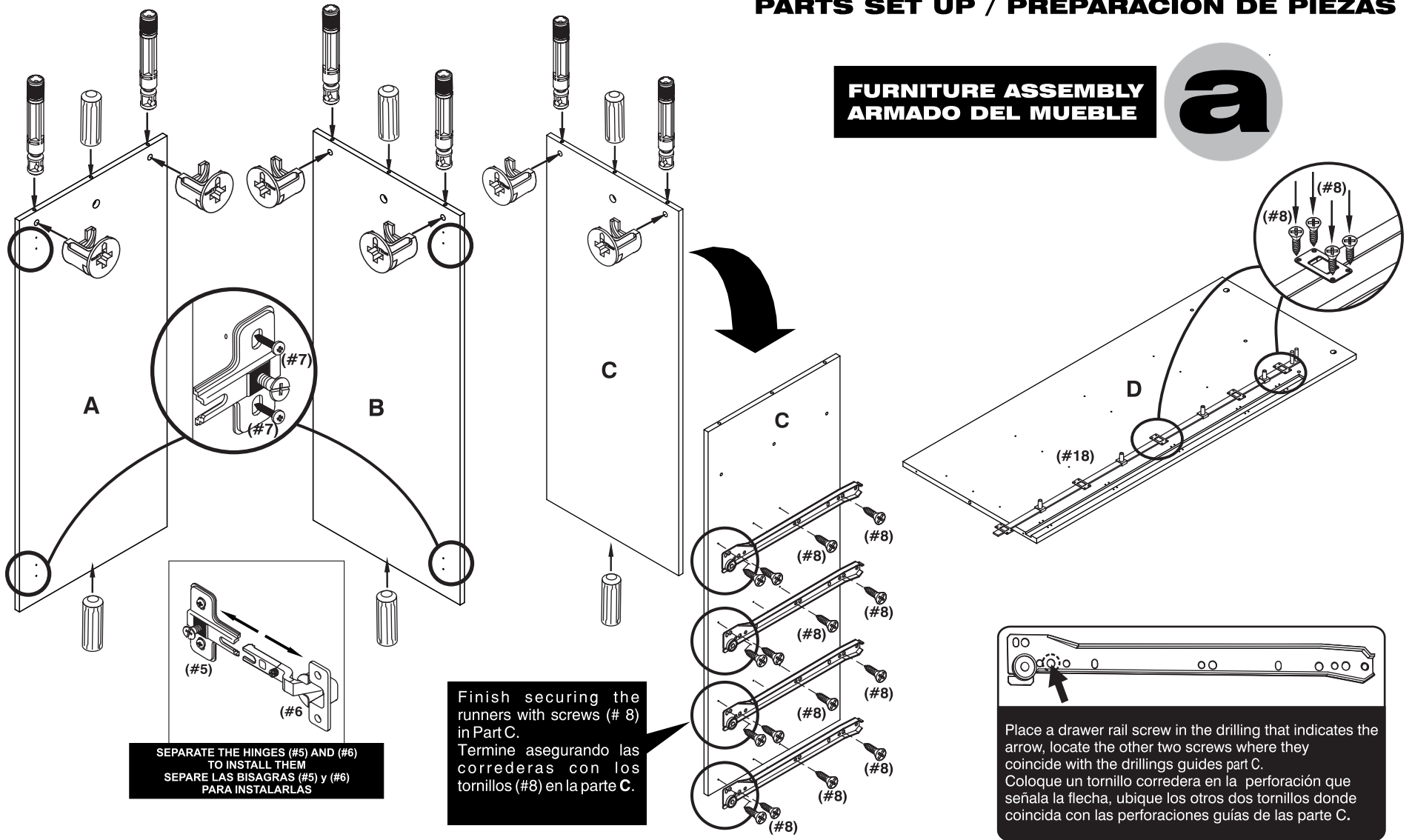

SEPARATE THE HINGES (#5) AND (#6) TO INSTALL THEM
SEPARA LAS BISAGRAS (#5) y (#6) PARA INSTALARLAS

Finish securing the runners with screws (# 8) in Part C.
Termine asegurando las correderas con los tornillos (#8) en la parte C.

Place a drawer rail screw in the drilling that indicates the arrow, locate the other two screws where they coincide with the drillings guides part C.
Coloque un tornillo corredera en la perforación que señala la flecha, ubique los otros dos tornillos donde coincida con las perforaciones guías de las parte C.

FOR THIS STEP, YOU WILL NEED:
EN ESTE PASO NECESITA:

**TOOLS
HERRAMIENTAS**

MARTILLO /HAMMER **PHILLIPS SCREWDRIVER / ATORNILLADOR DE ESTRELLA**

**HARDWARE
HERRAJES**

(# 1) WOODEN DOWELS / TARUGOS (# 2) CAM STUDS / PERNOS (# 3) CAMS STUDS / TUERCAS (# 5) HINGES / BISAGRAS

(# 7) SCREWS HINGES/ BRACKETS / TORNILLOS BISAGRA/PLATINA (# 8) SCREWS RAILS / TORNILLOS CORREDERAS/ PLATINAS/ (# 18) LOCK STRIP / LISTON CHAPA (# 10) SLIDES / CORREDERAS

1/2" 13.0 mm

2 ASSEMBLY STEPS / PASOS PARA ENSAMBLAR

PARTS SET UP / PREPARACIÓN DE PIEZAS

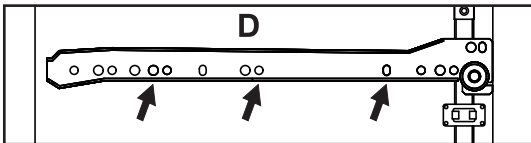
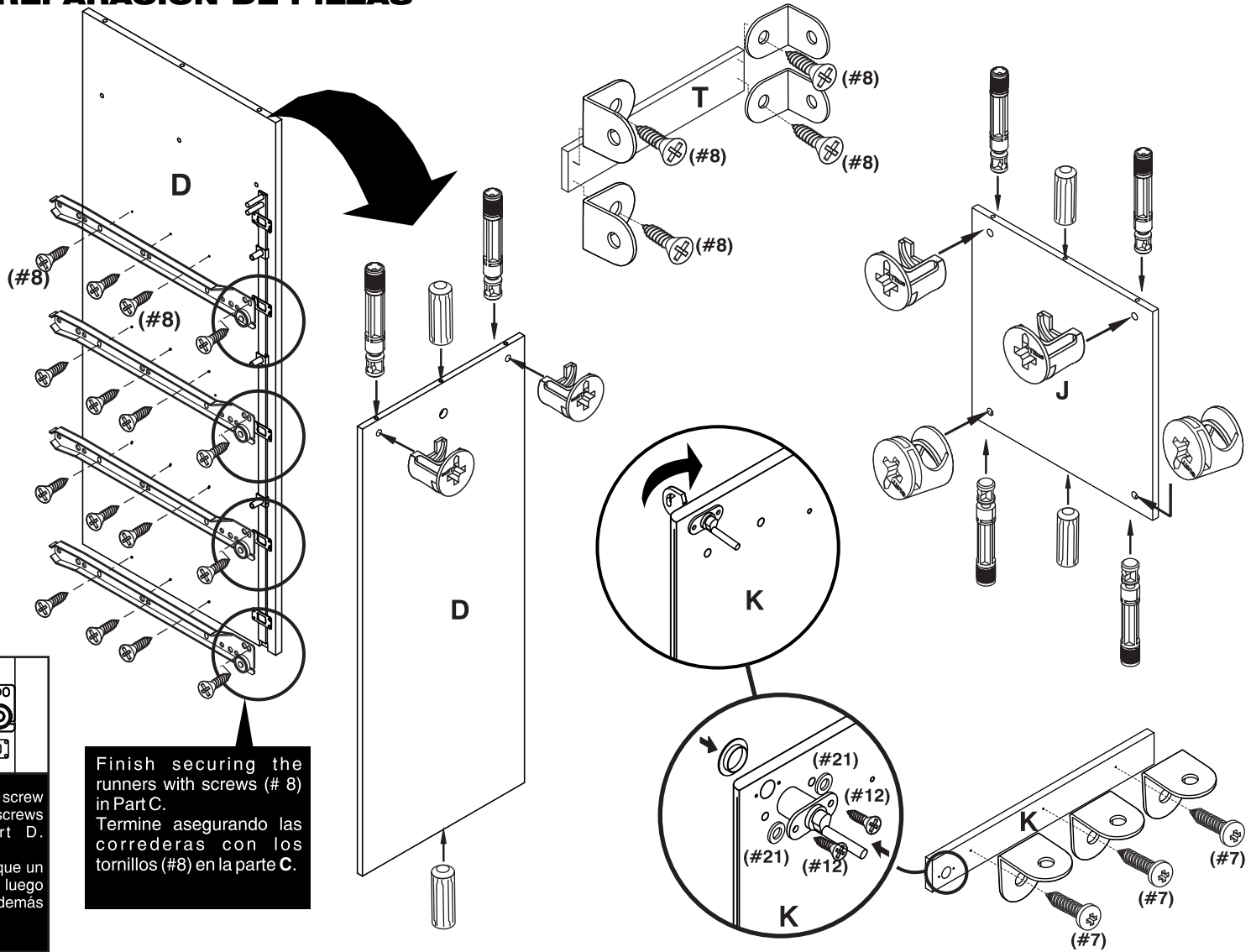

Place the slides on edge of Part D, and place a sliding screw perforation of the arrow, then locate where the other two screws match the holes in the other guides part D.

Coloque la correderas en el borde de la parte D, y coloque un tornillo corredera en la perforación que indica la flecha, luego ubique los otros dos tornillos donde coincida con las demás perforaciones guías de la parte D.

Finish securing the runners with screws (# 8) in Part C.
Termine asegurando las correderas con los tornillos (#8) en la parte C.

FOR THIS STEP, YOU WILL NEED:
EN ESTE PASO NECESITA:

TOOLS
HERRAMIENTAS

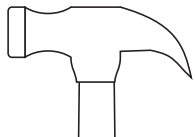

MARTILLO
/HAMMER



PHILLIPS SCREWDRIVER /
ATORNILLADOR DE ESTRELLA

HARDWARE
HERRAJES



(# 2)
CAM STUDS
PERNOS



(# 1)
WOODEN DOWELS
TARUGOS



(# 3)
CAMS STUDS
TUERCAS

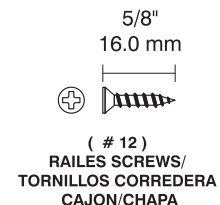
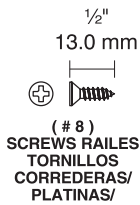

(# 10)
SLIDES
CORREDERAS

ASSEMBLY STEPS / PASOS PARA ENSAMBLAR 3

PARTS SET UP / PREPARACIÓN DE PIEZAS

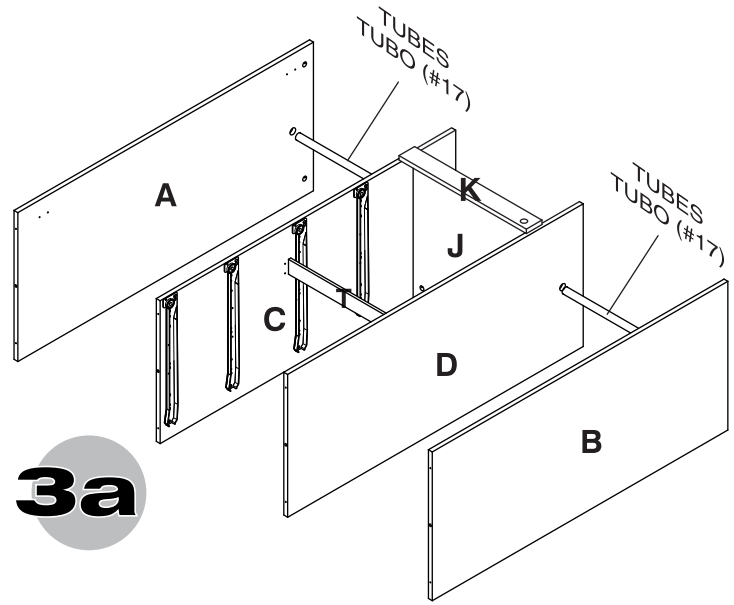
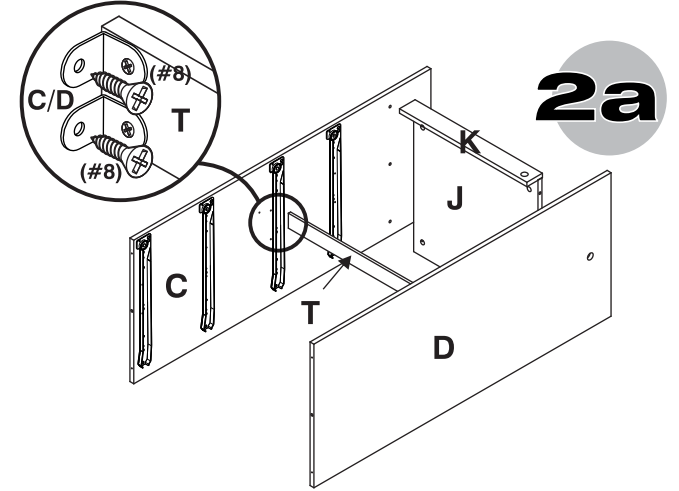
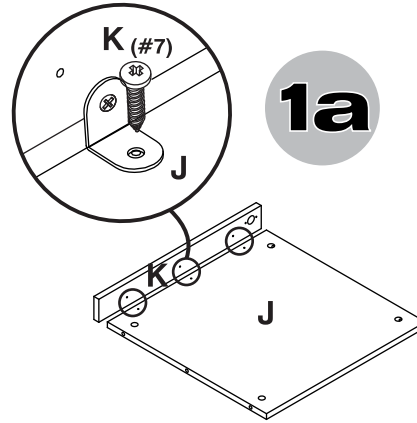
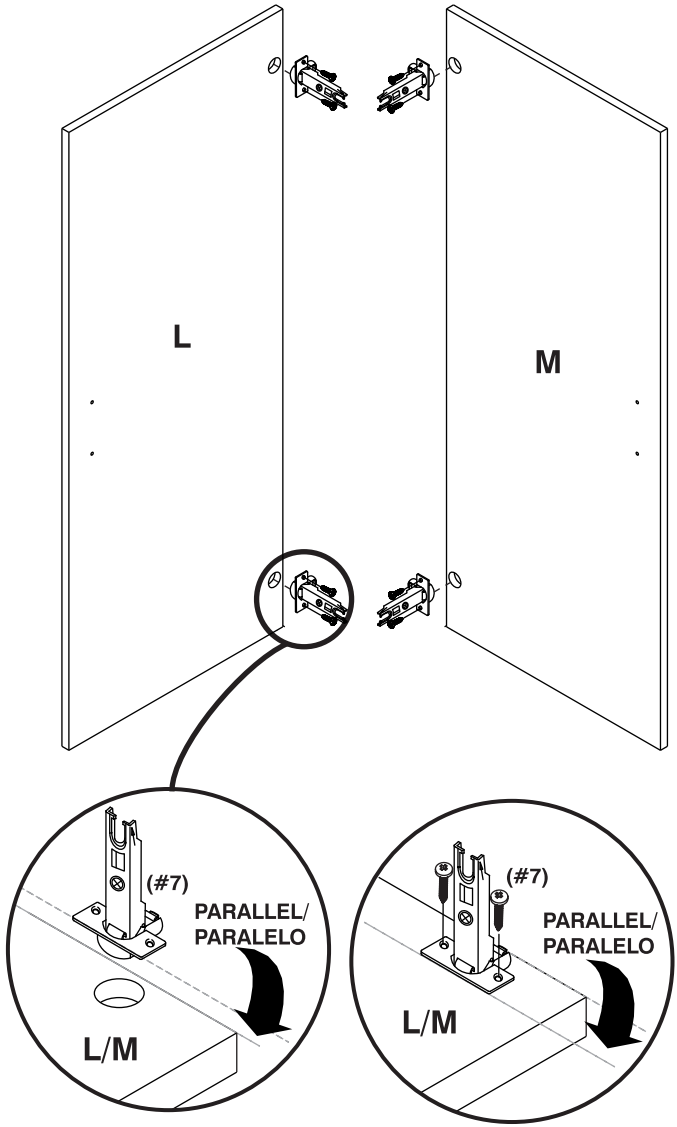

FOR THIS STEP, YOU WILL NEED:
EN ESTE PASO NECESITA:

TOOLS
HERRAMIENTAS

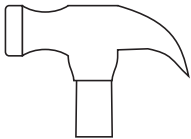

MARTILLO
/HAMMER



PHILLIPS SCREWDRIVER /
ATORNILLADOR DE ESTRELLA

HARDWARE
HERRAJES



(# 7)
SCREWS HINGES/
BRACKETS
TORNILLOS
BISAGRA/PLATINA



(# 8)
SCREWS RAILES
TORNILLOS
CORREDERAS/
PLATINAS/

1/2"
13.0 mm



(# 17)
TUBES
TUBOS

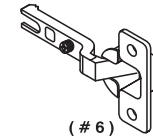

(# 6)
HINGES
BISAGRAS

4 ASSEMBLY STEPS / PASOS PARA ENSAMBLAR

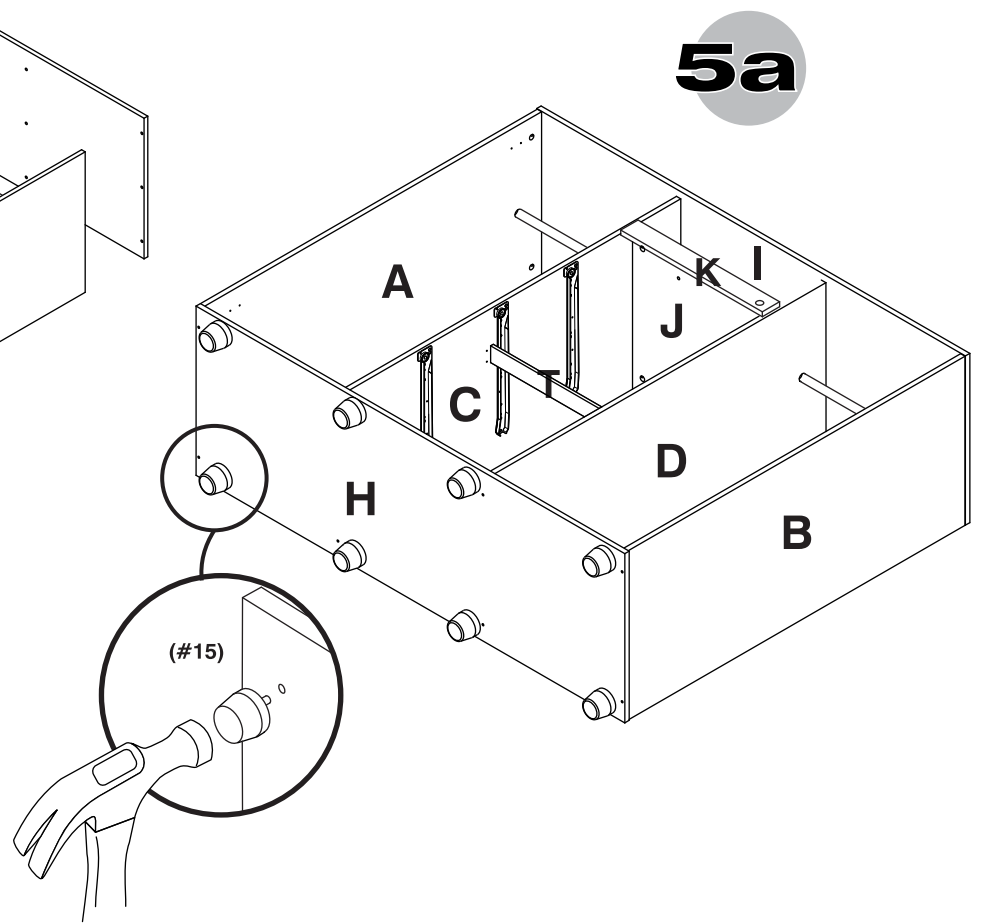
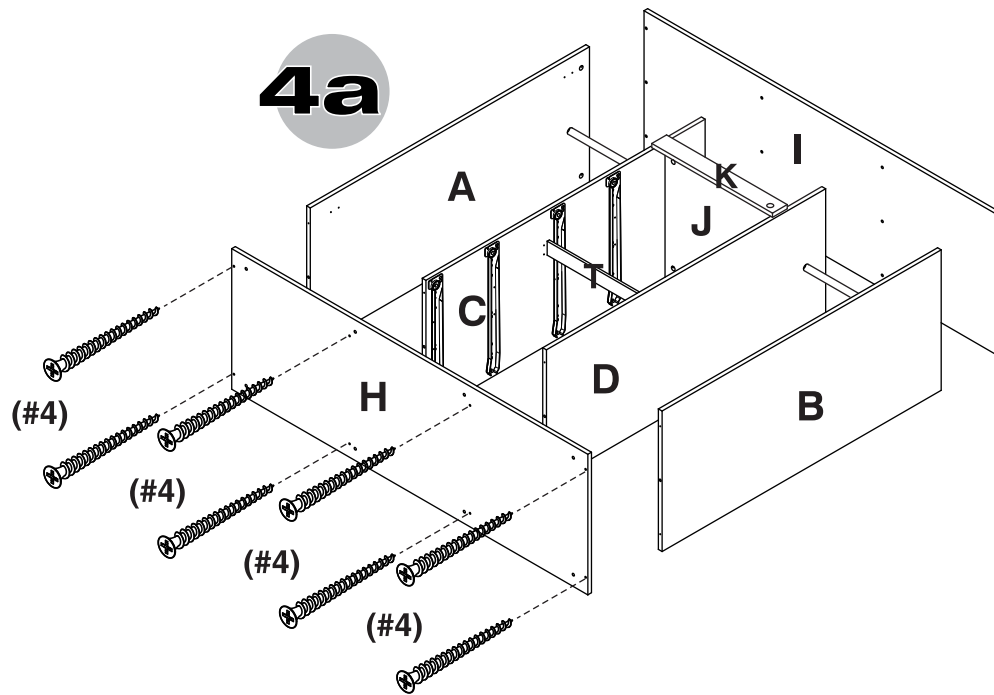

FOR THIS STEP, YOU WILL NEED:
EN ESTE PASO NECESITA:

TOOLS
HERRAMIENTAS

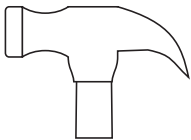

MARTILLO
/HAMMER



PHILLIPS SCREWDRIVER /
ATORNILLADOR DE ESTRELLA

HARDWARE
HERRAJES



(# 4)
DRYWALL SCREW
TORNILLOS
DRYWALL



(#15)
GLIDERS
DESLIZADORES

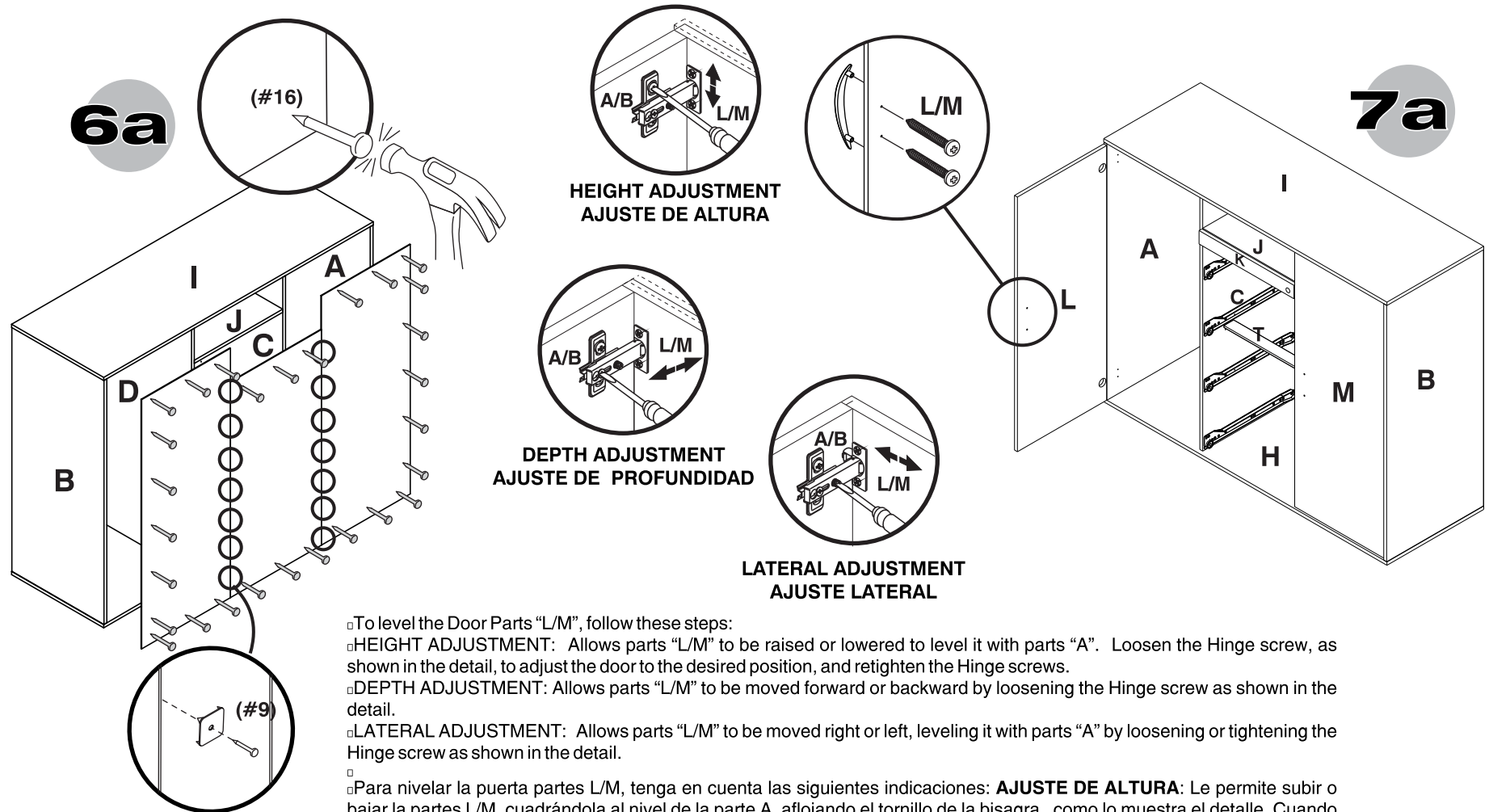

- To level the Door Parts "L/M", follow these steps:
- **HEIGHT ADJUSTMENT:** Allows parts "L/M" to be raised or lowered to level it with parts "A". Loosen the Hinge screw, as shown in the detail, to adjust the door to the desired position, and retighten the Hinge screws.
- **DEPTH ADJUSTMENT:** Allows parts "L/M" to be moved forward or backward by loosening the Hinge screw as shown in the detail.
- **LATERAL ADJUSTMENT:** Allows parts "L/M" to be moved right or left, leveling it with parts "A" by loosening or tightening the Hinge screw as shown in the detail.
- Para nivelar la puerta partes L/M, tenga en cuenta las siguientes indicaciones: **AJUSTE DE ALTURA:** Le permite subir o bajar la partes L/M, cuadrándola al nivel de la parte A, aflojando el tornillo de la bisagra, como lo muestra el detalle. Cuando este en el lugar indicado, asegure los tornillos bisagra. **AJUSTE DE PROFUNDIDAD:** Le permite llevar la partes L/M, hacia adentro o hacia afuera, aflojando el tornillo de la bisagra, como lo muestra el detalle. **AJUSTE LATERAL:** Le permite llevar la partes L/M, hacia la derecha o la izquierda, nivelándola con la parte A aflojando o apretando el tornillo de la bisagra, como lo muestra el detalle.

FOR THIS STEP, YOU WILL NEED:
EN ESTE PASO NECESITA:

TOOLS
HERRAMIENTAS

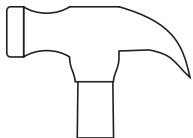

MARTILLO
/HAMMER



PHILLIPS SCREWDRIVER /
ATORNILLADOR DE ESTRELLA

HARDWARE
HERRAJES



(# 16)
NAILS
PUNTILLAS



WASHERS
ARANDELAS
(#9)



(# 13)
HANDLES
MANIJAS

6 ASSEMBLY STEPS / PASOS PARA ENSAMBLAR

PARTS SET UP / PREPARACIÓN DE PIEZAS

FURNITURE ASSEMBLY ARMADO DEL MUEBLE

b

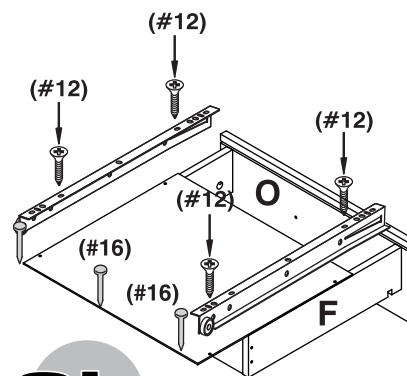
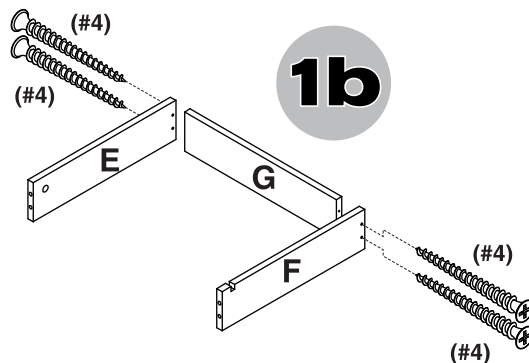
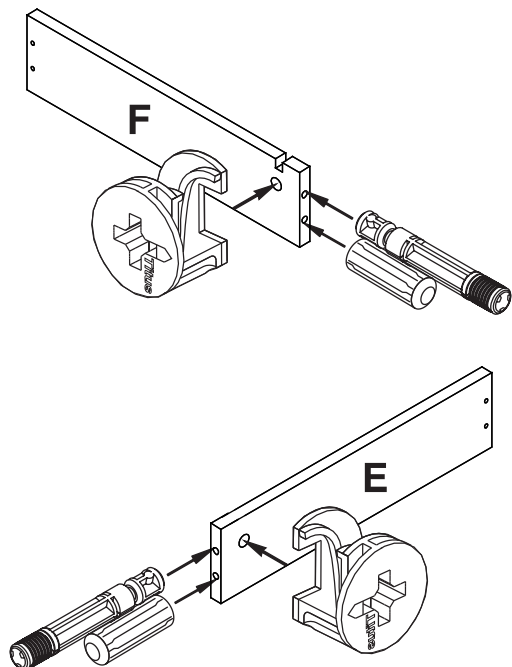

3b

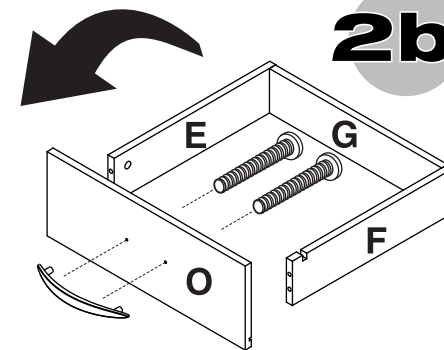

2b

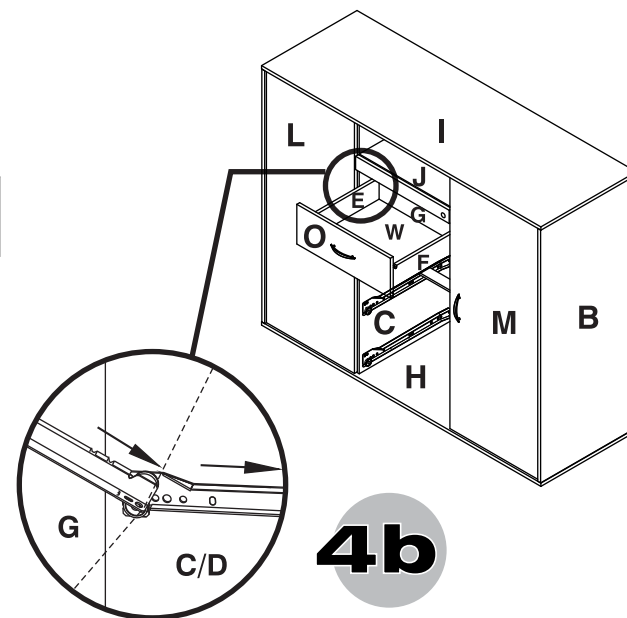

4b

FOR THIS STEP, YOU WILL NEED:
EN ESTE PASO NECESITA:

TOOLS
HERRAMIENTAS

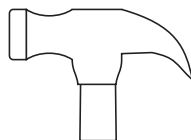

MARTILLO
/HAMMER

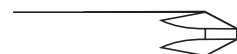

PHILLIPS SCREWDRIVER/
ATORNILLADOR DE ESTRELLA

HARDWARE
HERRAJES



(# 2)
CAM STUDS
PERNOS



(# 1)
WOODEN DOWELS
TARUGOS



(# 3)
CAM STUDS
TUERCAS



(# 11)
DRAWER RAILS
CORREDERAS
CAJON

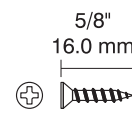

5/8"
16.0 mm
(# 12)
RAILES SCREWS
TORNILLOS CORREDERA
CAJON/CHAPA



(# 13)
HANDLES
MANIJAS



(# 4)
DRYWALL SCREW
TORNILLOS
DRYWALL



(# 16)
NAILS
PUNTILLAS

ASSEMBLY STEPS / PASOS PARA ENSAMBLAR 7

FURNITURE ASSEMBLY ARMADO DEL MUEBLE

C

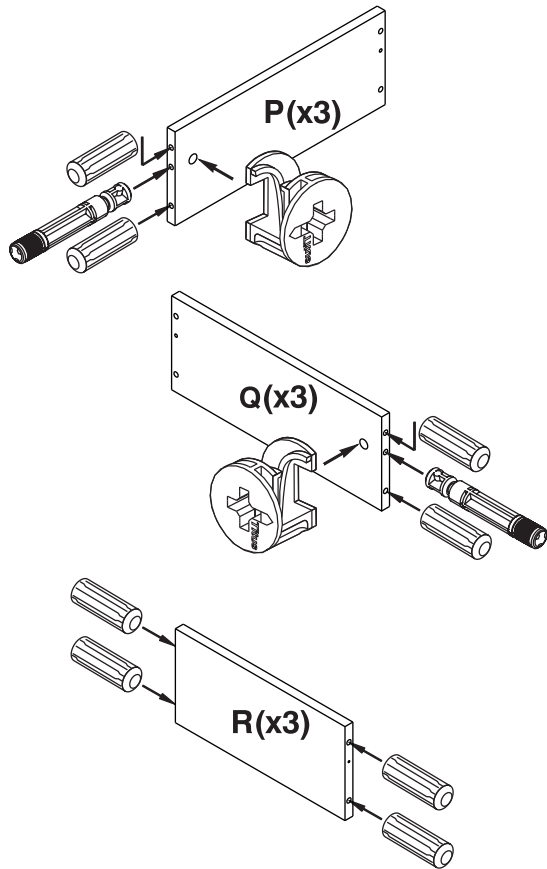

PARTS SET UP / PREPARACIÓN DE PIEZAS

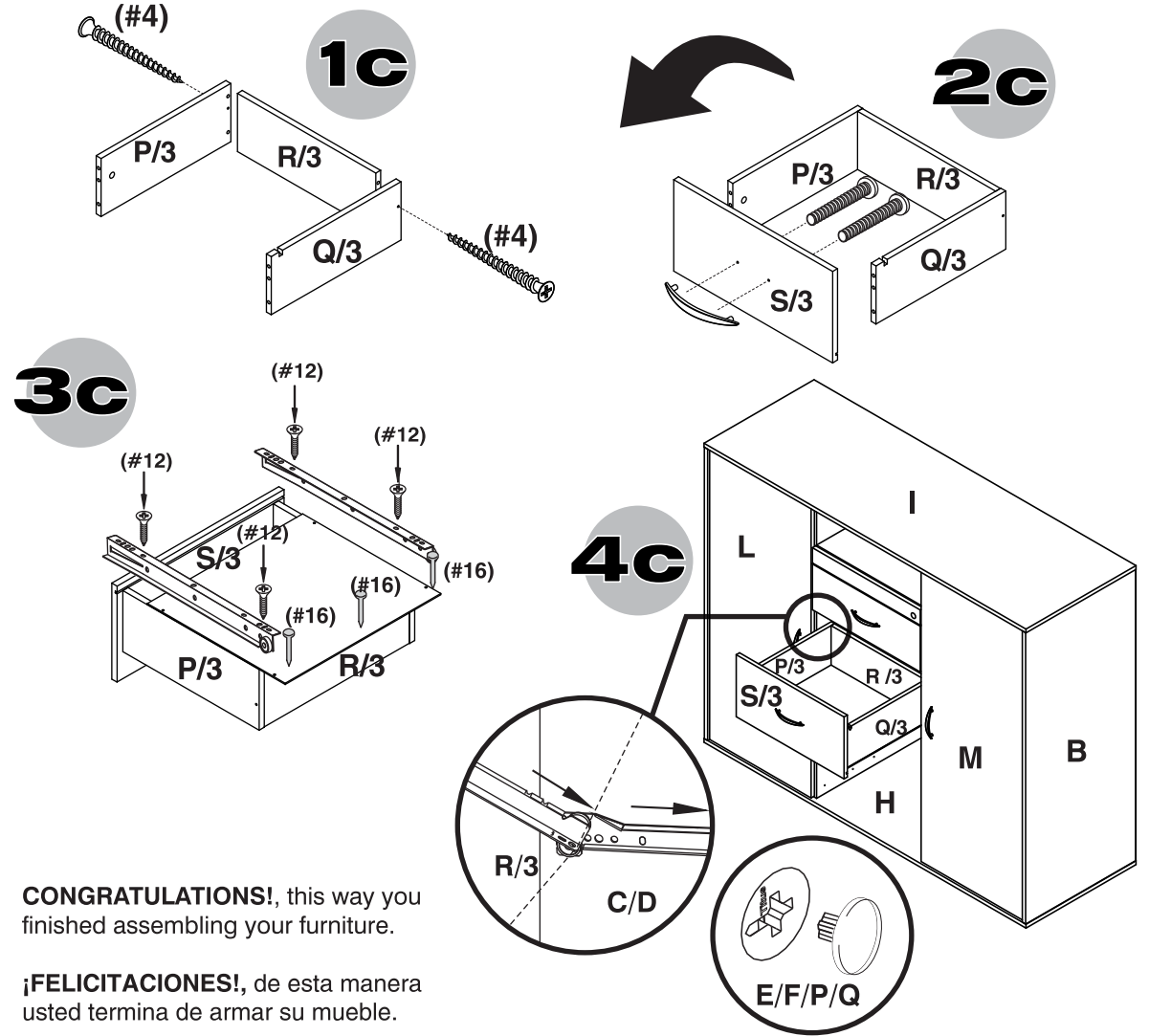

CONGRATULATIONS!, this way you finished assembling your furniture.

¡FELICITACIONES!, de esta manera usted termina de armar su mueble.

FOR THIS STEP, YOU WILL NEED:
EN ESTE PASO NECESITA:

TOOLS
HERRAMIENTAS

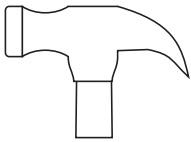

MARTILLO
/HAMMER

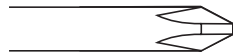

PHILLIPS SCREWDRIVER /
ATORNILLADOR DE ESTRELLA

HARDWARE
HERRAJES

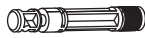

(# 2)
CAM STUDS
PERNOS



(# 1)
WOODEN DOWELS
TARUGOS



(# 3)
CAM STUDS
TUERCAS

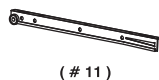

(# 11)
DRAWER RAILS
CORREDERAS
CAJON



(# 13)
HANDLES
MANIJAS

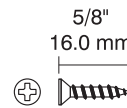

(# 12)
RAILES SCREWS
TORNILLOS CORREDERA
CAJON/CHAPA



(# 20)
CAM CAPS
TAPAS TUERCA



(# 16)
NAILS
PUNTILLAS

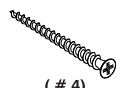

(# 4)
DRYWALL SCREW
TORNILLOS
DRYWALL